

PORTER CABLE®

10 IN. (254 MM) DRILL PRESS

**PERCEUSE À COLONNE DE 254 MM
(10 PO)**

**254 MM (10 PULGADAS)
PERFORADORA DE COLUMNA**

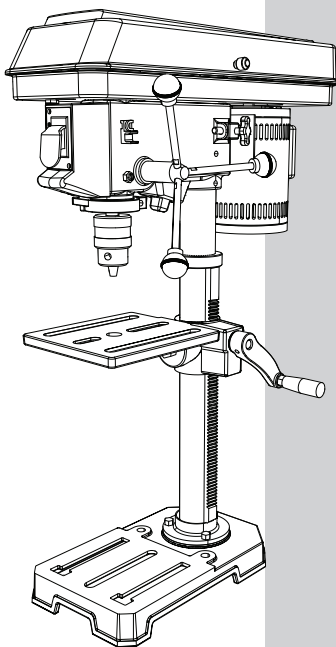

Instruction Manual
Manuel d'instructions
Manual de instrucciones

www.portercable.com

INSTRUCTIVO DE OPERACIÓN,
CENTROS DE SERVICIO Y PÓLIZA
DE GARANTÍA.

⚠ ADVERTENCIA: LÉASE ESTE
INSTRUCTIVO ANTES DE USAR EL
PRODUCTO.

**CATALOG NUMBER
PCXB620DP**

TABLE OF CONTENTS

SECTION	PAGE
PRODUCT SPECIFICATIONS	2
CALIFORNIA PROPOSITION 65.....	3
SAFETY GUIDELINES - DEFINITIONS	3
POWER TOOL SAFETY	4
ADDITIONAL SAFETY RULES FOR DRILL PRESSES.....	6
ELECTRICAL REQUIREMENTS AND SAFETY	8
TOOLS NEEDED FOR ASSEMBLY	10
CARTON CONTENTS	10
KNOW YOUR DRILL PRESS	12
GLOSSARY OF TERMS.....	13
ASSEMBLY AND ADJUSTMENTS	14
OPERATION	19
MAINTENANCE	23
ACCESSORIES AND ATTACHMENTS	23
TROUBLESHOOTING GUIDE	24
PARTS LIST.....	26
WARRANTY.....	28

PRODUCT SPECIFICATIONS

MOTOR

Power Source 120 V, 60 Hz, 3.2 A
 Speed (No load) .. 1720 RPM
 Type Induction
 Volts 120 volts AC only

LAMP..... Yes

Spindle Travel 2 in. (50 mm)
 Speeds (RPM) 610~2800 RPM
 Chuck Size 1/2 in. (12.7 mm)
 Column Size 1-7/8 in. (48 mm)

TABLE

Size 7-5/8 in. x 6-1/2 in.
 (194 x 165 mm)

BASE

Size 12-1/2 in. x 7-5/16 in.
 (319 x 186 mm)
 Chuck to Column 5 in. (127 mm)
 Chuck to Base 16-9/64 in. (410 mm)

WARNING

To avoid electrical hazards, fire hazards or damage to the tool, use proper circuit protection. Use a separate electrical circuit for your tools. The drill press is wired at the factory for 120 Volt operation. It must be connected to a 120 V, 3.2 AMP branch circuit and use a 3.2 AMP time delay fuse or circuit breaker. To avoid shock or fire, replace power cord immediately if it is worn, cut or damaged in any way.

CALIFORNIA PROPOSITION 65

WARNING

Some dust created by power sanding, sawing, grinding, drilling and other construction activities contains chemicals known to the state of California to cause cancer, birth defects or other reproductive harm. Some examples of these chemicals are:

- Lead from lead-based paints,
- Crystalline silica from bricks and cement and other masonry products, and
- Arsenic and chromium from chemically-treated lumber.

Your risk from these exposures varies, depending on how often you do this type of work. To reduce your exposure to these chemicals: work in a well ventilated area, and work with approved safety equipment, such as those dust masks that are specially designed to filter out microscopic particles.

Avoid prolonged contact with dust from power sanding, sawing, grinding, drilling and other construction activities. Wear protective clothing and wash exposed areas with soap and water. Allowing dust to get into your mouth, eyes, or lay on the skin may promote absorption of harmful chemicals.

WARNING

Use of this tool can generate and/or disperse dust, which may cause serious and permanent respiratory or other injury. Always use NIOSH/OSHA approved respiratory protection appropriate for the dust exposure. Direct particles away from face and body.

SAFETY GUIDELINES - DEFINITIONS

WARNING ICONS

Your power tool and its Instruction Manual may contain “WARNING ICONS” (a picture symbol intended to alert you to and/or instruct you how to avoid a potentially hazardous condition). Understanding and heeding these symbols will help you operate your tool better and safer. Shown below are some of the symbols you may see.



SAFETY ALERT: Precautions that involve your safety.



PROHIBITION



WEAR EYE PROTECTION: Always wear safety goggles or safety glasses with side shields.



WEAR RESPIRATORY AND HEARING PROTECTION: Always wear respiratory and hearing protection.



READ AND UNDERSTAND INSTRUCTION MANUAL: To reduce the risk of injury, user and all bystanders must read and understand instruction manual before using this product.



KEEP HANDS AWAY FROM THE MOVING PART AND CUTTING SURFACE: Failure to keep your hands away from the moving part and cutting surface will result in serious personal injury.



SUPPORT AND CLAMP WORK

DANGER

DANGER: Indicates an imminently hazardous situation which, if not avoided, will result in death or serious injury.

WARNING

WARNING: Indicates a potentially hazardous situation which, if not avoided, could result in death or serious injury.

CAUTION

CAUTION: Indicates a potentially hazardous situation which, if not avoided, may result in minor or moderate injury.

CAUTION





CAUTION: Used without the safety alert symbol indicates potentially hazardous situation which, if not avoided, may result in property damage.



POWER TOOL SAFETY

GENERAL SAFETY INSTRUCTIONS BEFORE USING THIS POWER TOOL

Safety is a combination of common sense, staying alert and knowing how to use your power tool.

WARNING

- **To avoid mistakes that could cause serious injury, do not plug the tool in until you have read and understood the following.**
 - **Read all instructions before operating product. Failure to follow all instructions listed below may result in electric shock, fire and/or serious injury.**
1.  **READ** and become familiar with the entire Instruction Manual. **LEARN** the tool's application, limitations and possible hazards.
 2. **KEEP GUARDS IN PLACE** and in working order.
 3. **REMOVE ADJUSTING KEYS AND WRENCHES.** Form the habit of checking to see that keys and adjusting wrenches are removed from the tool before turning ON.
 4. **KEEP WORK AREA CLEAN.** Cluttered areas and benches invite accidents.
 5. **DO NOT USE IN DANGEROUS ENVIRONMENTS.** Do not use power tools in damp locations, or expose them to rain or snow. Keep work area well lit.
 6. **KEEP CHILDREN AWAY.** All visitors and bystanders should be kept a safe distance from work area.
 7. **MAKE WORKSHOP CHILD PROOF** with padlocks, master switches or by removing starter keys.
 8. **DO NOT FORCE THE TOOL.** It will do the job better and safer at the rate for which it was designed.
 9. **USE THE RIGHT TOOL.** Do not force the tool or an attachment to do a job for which it was not designed.
 10. **USE PROPER EXTENSION CORDS.** Make sure your extension cord is in good condition. When using an extension cord, be sure to use one heavy enough to carry the current your product will draw. An undersized cord will result in a drop in line voltage and in loss of power which will cause the tool to overheat. The table on page 9 shows the correct size to use depending on cord length and nameplate ampere rating. If in doubt, use the next heavier gauge. The smaller the gauge number, the heavier the cord.
 11. **WEAR PROPER APPAREL.** Do not wear loose clothing, gloves, neckties, rings, bracelets or other jewelry which may get caught in moving parts. Nonslip footwear is recommended. Wear protective hair covering to contain long hair.
 12.  **ALWAYS WEAR EYE PROTECTION.** Any power tool can throw foreign objects into the eyes and could cause permanent eye damage. **ALWAYS** wear Safety Goggles (not glasses) that comply with ANSI Safety standard Z87.1. Everyday eyeglasses have only impact-resistant lenses. They **ARE NOT** safety glasses. **NOTE:** Glasses or goggles not in compliance with ANSI Z87.1 could seriously injure you when they break.
 13.  **WEAR A FACE MASK OR DUST MASK.** Sawing operation produces dust.
 14.  **SECURE WORK.** Use clamps or a vise to hold work when practical. It is safer than using your hand and it frees both hands to operate the tool.
 15. **DISCONNECT TOOLS FROM POWER SOURCE** before servicing, and when changing accessories such as blades, bits and cutters.

16. **REDUCE THE RISK OF UNINTENTIONAL STARTING.** Make sure switch is in the OFF position before plugging the tool in.
17. **USE RECOMMENDED ACCESSORIES.** Consult this Instruction Manual for recommended accessories. The use of improper accessories may cause risk of injury to yourself or others.
18. **NEVER STAND ON THE TOOL.** Serious injury could occur if the tool is tipped or if the cutting tool is unintentionally contacted.
19. **CHECK FOR DAMAGED PARTS.** Before further use of the tool, a guard or other part that is damaged should be carefully checked to determine that it will operate properly and perform its intended function – check for alignment of moving parts, binding of moving parts, breakage of parts, mounting and any other conditions that may affect its operation. A guard or other part that is damaged should be properly repaired or replaced.
20. **NEVER LEAVE THE TOOL RUNNING UNATTENDED. TURN THE POWER “OFF”.** Do not walk away from a running tool until the blade comes to a complete stop and the tool is unplugged from the power source.
21. **DO NOT OVERREACH.** Keep proper footing and balance at all times.
22. **MAINTAIN TOOLS WITH CARE.** Keep tools sharp and clean for best and safest performance. Follow instructions for lubricating and changing accessories.
23. **DO NOT** use power tool in presence of flammable liquids or gases.
24. **DO NOT** operate the tool if you are under the influence of any drugs, alcohol or medication that could affect your ability to use the tool properly.
25. Dust generated from certain materials can be hazardous to your health. Always operate saw in well-ventilated area and provide for proper dust removal.
26.  **WARNING**
People with electronic devices, such as pacemakers, should consult their physician(s) before using this product. Operation of electrical equipment in close proximity to a heart pacemaker could cause interference or failure of the pacemaker.
27.  **WEAR HEARING PROTECTION** to reduce the risk of induced hearing loss.

ADDITIONAL SAFETY RULES FOR DRILL PRESS

Following good safety practices when using drill presses is a must. Make a habit of including safety in all your activities.

WARNING

READ ALL INSTRUCTIONS BEFORE OPERATING PRODUCT. FAILURE TO FOLLOW ALL INSTRUCTIONS LISTED BELOW MAY RESULT IN ELECTRIC SHOCK, FIRE AND OR SERIOUS INJURY. Do not operate this tool until it is assembled and installed according to the instructions.

- 1. YOUR DRILL PRESS MUST BE BOLTED** securely to a workbench. In addition, if there is any tendency for your drill press to move during certain operations, bolt the workbench to the floor.
- 2. DO NOT** try to drill material too small to be securely held.
- 3. ALWAYS** keep hands out of the path of a drill bit. Avoid awkward hand positions where a sudden slip could cause your hand to move into the drill bit.
- 4. DO NOT** install or use any drill bit that exceeds 7 in. (175 mm) in length or extends 6 in. (150 mm) below the chuck jaws. They can suddenly bend outward or break.
- 5. DO NOT USE** wire wheels, router bits, shaper cutters, circle (fly) cutters, or rotary planers on this drill press.
- 6. WHEN** cutting a large piece of material, make sure it is fully supported at the table height.
- 7. NEVER** hold the work piece by hand. Secure the work piece with a clamp or another appropriate fixture if it is not long enough to be braced against the table column.
- 8. CLAMP THE WORKPIECE OR BRACE IT** against the left side of the column to prevent rotation. If it is too short or the table is tilted, clamp it solidly to the table.
- 9. IF THE WORKPIECE** overhangs the table such that it will fall or tip if not held, clamp it to the table or provide auxiliary support.
- 10. SECURE THE WORK.** Use clamps or a vise to hold the work. It's safer than using your hand and it frees both hands to operate tool.
- 11. WHEN** using a drill press vise, always fasten to the table.
- 12. MAKE SURE** all clamps and locks are firmly tightened before drilling.
- 13. MAKE SURE** there are no nails or foreign objects in the part of the workpiece to be drilled.
- 14. SECURELY LOCK THE HEAD** and table support to the column, and the table to the table support before operating the drill press.
- 15. NEVER** turn your drill press on before clearing the table of all objects (tools, scraps of wood, etc.). Remove material or debris from the area that might be ignited by hot chips.
- 16.** Crowded, cluttered work areas that can cause tripping or loss of balance are particularly dangerous.
- 17. BEFORE STARTING** the operation, jog the motor switch to make sure the drill bit does not wobble or vibrate.
- 18. LET THE SPINDLE REACH FULL SPEED** before starting to drill. If your drill press makes an unfamiliar noise or if it vibrates excessively, stop immediately, turn the drill press off and unplug. Do not restart the unit until the problem is corrected.
- 19. DO NOT** perform layout assembly or set up work on the table while the drill press is in operation.
- 20. USE THE RECOMMENDED SPEED** for any drill press accessory and for different workpiece material. **READ THE INSTRUCTIONS** that come with the accessory.
- 21. WHEN DRILLING** large diameter holes, clamp the workpiece firmly to the table. Otherwise, the bit may grab and spin the workpiece at high speeds. **DO NOT USE** fly cutters or multiple-part hole cutters, as they can come apart or become unbalanced in use.

22. **DO NOT** use bits with screw tips. These bits will pull the workpiece up from the table and start to spin, causing a serious risk of injury.
23. **MAKE SURE** the spindle has come to a complete stop before touching the workpiece.
24. **TO AVOID INJURY** from accidental starting, always turn the switch "OFF" and unplug the drill press before installing or removing any accessory or attachment or making any adjustment.
25. Be sure the chuck is tightly secured to the spindle.
26. **USE ONLY THE SELF-EJECTING TYPE CHUCK KEY** as provided with the drill press. Tighten the bit securely in the chuck. The chuck key can be thrown at a high velocity if not removed, causing risk for injury.
27. **DO NOT FORCE DRILLING.** The tool will do the job better and safer at the rate for which it is was intended.
28. If the bit binds in the workpiece, release the on/off switch immediately. Unplug the tool, then free the bit from the workpiece. Do not try to free a jammed bit by starting and stopping the tool.
29. **DO NOT** touch the drill bit or cuttings. The drill bit and cuttings are hot immediately after drilling.
30. **ALWAYS** shut off, unplug and lock the drill press, if a lock in available, and store the key.

ELECTRICAL REQUIREMENTS AND SAFETY

POWER SUPPLY AND MOTOR SPECIFICATIONS

⚠ WARNING

To avoid electrical hazards, fire hazards, or damage to the tool, use proper circuit protection. Use a separate electrical circuit for your tool. Your grinder is wired at the factory for 120 V operation. Connect to a 120 V, 3.2 Amp circuit and use a 3.2 Amp time delay fuse or circuit breaker. To avoid shock or fire, if power cord is worn, cut, or damaged in any way, have it replaced immediately.

GROUNDING INSTRUCTIONS

⚠ WARNING

This tool must be grounded while in use to protect the operator from electrical shock.

IN THE EVENT OF A MALFUNCTION OR BREAKDOWN, grounding provides a path of least resistance for electric currents and reduces the risk of electric shock. This tool is equipped with an electrical cord that has an equipment-grounding conductor and a grounding plug. The plug must be plugged into a matching receptacle that is properly installed and grounded in accordance with all local codes and ordinances.

DO NOT MODIFY THE PLUG PROVIDED.

If it will not fit the receptacle, have the proper receptacle installed by a qualified electrician.

IMPROPER CONNECTION of the equipment grounding conductor can result in risk of electric shock. The conductor with the green insulation (with or without yellow stripes) is the equipment grounding conductor. If repair or replacement of the electrical cord or plug is necessary, do not connect the equipment grounding conductor to a live terminal.

CHECK with a qualified electrician or service person if you do not completely understand the grounding instructions, or if you are not certain the tool is properly grounded.

USE only 3-wire extension cords that have three-pronged grounding plugs with three-pole receptacles that accept the tool's plug. Repair or replace damaged or worn cords immediately.

Use a separate electrical circuit for your tool. This circuit must not be less than #18 wire and should be protected with a 3.2 Amp time lag fuse. Before connecting the motor to the power line, make sure the switch is in the off position and the electric current is rated the same as the current stamped on the motor nameplate. Running at a lower voltage will damage the motor.

GUIDELINES FOR EXTENSION CORDS USE THE PROPER EXTENSION CORD.

Make sure your extension cord is in good condition. Use an extension cord heavy enough to carry the current your product will draw. An undersized cord will cause a drop in line voltage resulting in loss of power, overheating and burning out of the motor. The table below shows the correct size to use depending on cord length and nameplate ampere rating. If in doubt, use the next heavier gauge. The smaller the gauge number, the heavier the cord.

Make sure your extension cord is properly wired and in good condition. Always replace a damaged extension cord or have it repaired by a qualified technician before using it. Protect your extension cords from sharp objects, excessive heat and damp or wet areas.

MINIMUM GAUGE FOR EXTENSION CORDS (AWG)				
(When using 120 volts only)				
Ampere Rating		Total length of Cord		
More Than	Not More Than	25 (7.62)	50 15.24	100 30.48
		150 45.72	ft. m)	
AWG- American Wire Gauge				
0	6	18	16	14
6	10	18	16	14
10	12	16	16	14
12	16	14	12	Not Recommended

⚠ WARNING

This tool is for indoor use only. Do not expose to rain or use in damp locations.

This tool is intended for use on a circuit that has a receptacle like the one illustrated in Fig. 1. Fig. 1 shows a three-pronged electrical plug and receptacle that has a grounding conductor. If a properly grounded receptacle is not available, an adapter (Fig. 2) can be used to temporarily connect this plug to a two-contact grounded receptacle. The adapter (Fig. 2) has a rigid lug extending from it that **MUST** be connected to a permanent earth ground, such as a properly grounded receptacle box.

⚠ CAUTION

In all cases, make certain the receptacle is properly grounded. If you are not sure, have a qualified electrician check the receptacle.

Fig. 1

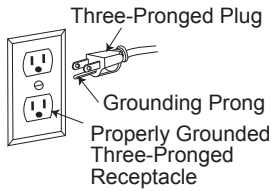
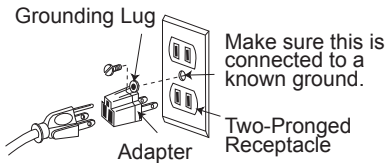

Fig. 2



TOOLS NEEDED FOR ASSEMBLY

Supplied



3 mm hex key



4 mm hex key

Not Supplied



Slotted screwdriver

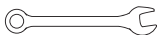

Wrench



Adjustable wrenches



Combination square

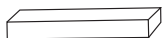

Block of wood

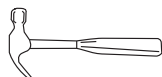

Hammer or rubber mallet

CARTON CONTENTS

UNPACKING AND CHECKING CONTENTS

Carefully unpack the drill press and all its parts, and compare against the list below and the illustration on the next page. Place the drill press on a secure surface and examine it carefully.

⚠ WARNING

- To avoid injury from unexpected starting or electrical shock, do not plug the power cord into a source of power during unpacking and assembly. The cord must remain unplugged whenever you are adjusting/assembling the drill press.
- The drill press is heavy and should be lifted with care. If needed, get the assistance of someone to lift and move the drill press.
- If any part is missing or damaged, do not attempt to assemble the drill press, or plug in the power cord until the missing or damaged part is correctly replaced.

TABLE OF LOOSE PARTS

ITEM	DESCRIPTION	Q'TY
A.	Head Assembly	1
B.	Table Assembly	1
C.	Base	1
D.	Feed Handles	3
E.	Chuck & Key Hardware	
	Chuck	1
	Chuck Key	1
F.	Column Assembly	1
G.	Hardware Bag	
	Lock Handle	1
	Crank Handle	1
	Worm Gear	1
	Hex Wrenches	2
	Hex Bolts	3
	Rack	1
	Rack Ring	1
H.	Aa Batteries	2

UNPACKING YOUR DRILL PRESS

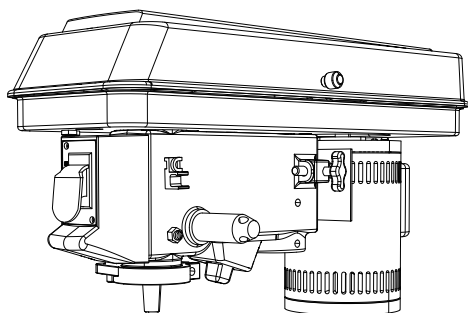

A

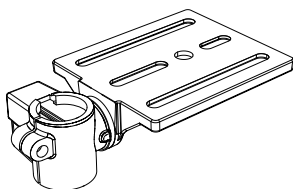

B

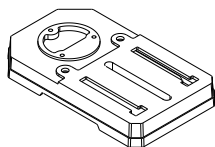

C



D

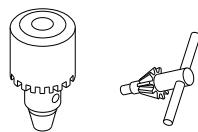

E

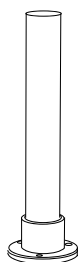

F

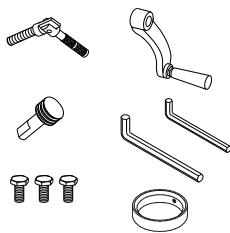

G



H

KNOW YOUR DRILL PRESS

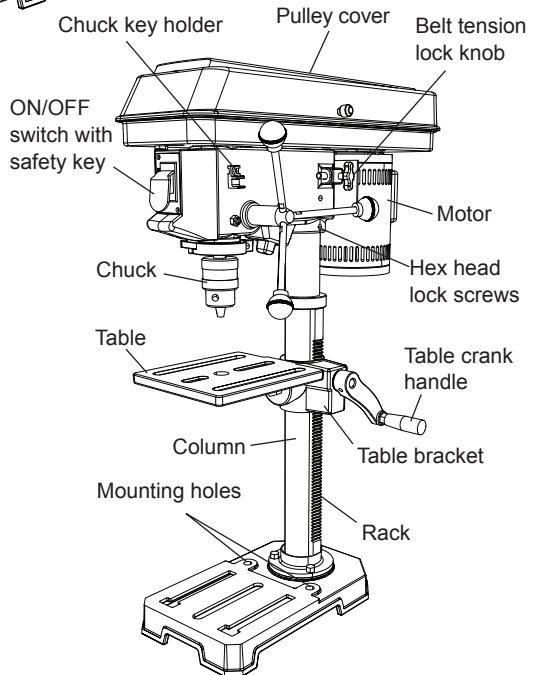
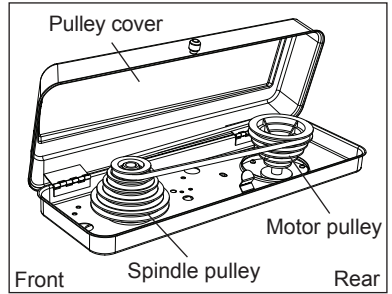
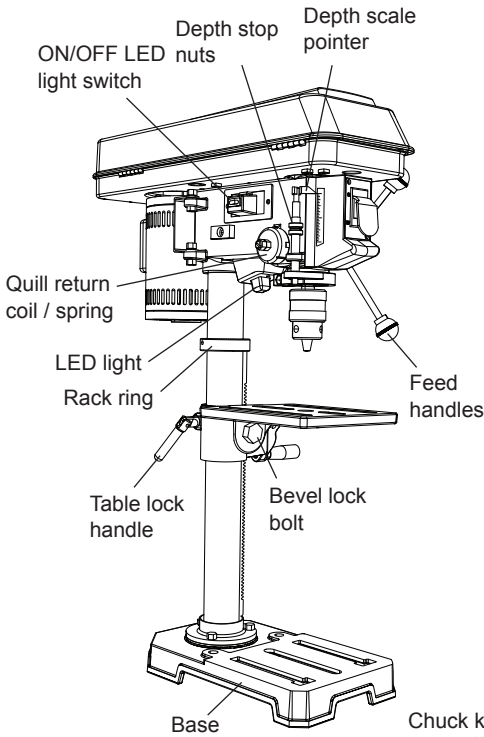

GLOSSARY OF TERMS

BASE – Supports drill press. For additional stability, holes are provided in the base to bolt drill press to the floor. (See “ADDITIONAL SAFETY RULES FOR DRILL PRESSES”.)

BACKUP MATERIAL – A piece of scrap wood placed between the workpiece and table. The backup board prevents wood in the workpiece from splintering when the drill passes through the backside of the workpiece. It also prevents drilling into the table top.

PULLEY COVER – Covers the pulleys and belt during operation of the drill press.

BELT TENSION – Refer to the “Assembly” Section, “Installing and Tensioning Belt.”

BELT TENSION LOCK KNOBS – Tightening the knobs locks the motor bracket support and the belt tension handle, maintaining correct belt distance and tension.

BEVEL SCALE – Shows degree of table tilt for bevel operations. The scale is mounted on the side of the arm.

CHUCK – Holds a drill bit or other recommended accessory to perform desired operations.

CHUCK KEY – A self-ejecting chuck key which will pop out of the chuck when you let go of it. This action is designed to help prevent throwing of the chuck key from the chuck when the power is turned “ON.” Do not use any other key as a substitute; order a new one if damaged or lost.

COLUMN ASSEMBLY – Connects the head, table, and base on a one piece tube for easy alignment and movement. Mounts to base.

COLUMN COLLAR – Holds the rack to the column. Rack remains movable in the collar to permit table support movements.

DEPTH SCALE STOP NUTS – Lock the spindle to a selected depth.

DEPTH SCALE – Indicates depth of hole being drilled.

DRILL BIT – The cutting tool used in the drill press to make holes in a workpiece.

ON/OFF SWITCH – Has locking feature. This feature is intended to help prevent unauthorized and possible hazardous use by children and others. Insert the key into the switch to turn the drill press on.

DRILLING SPEED – Changed by placing the belt in any of the steps (grooves) in the pulleys. See the Spindle Speed Chart inside belt guard.

FEED HANDLES – Moves the chuck up or down. One or two of the handles may be removed if necessary whenever the workpiece is of such unusual shape that it interferes with the handles.

HEX HEAD LOCK SCREWS – Locks the head to the column. ALWAYS lock the head in place while operating the drill press.

LED LIGHT – or Worklight. This tool comes equipped with a worklight that provides additional light to the work area.

RACK – Combines with gear mechanism to provide easy elevation of the table by the hand operated table crank.

RACK RING – Hold the top of the rack in place on the column. Make sure this is tight before operating drill.

REVOLUTIONS PER MINUTE (R.P.M.) – The number of turns completed by a spinning object in one minute.

SPINDLE SPEED – The R.P.M. of the spindle.

SPRING CAP – Adjusts the quill return spring tension.

TABLE HANDLE LOCK – Tightens the table bracket to the column. Always have it locked in place while operating the drill press.

TABLE – Provides a working surface to support the workpiece.

TABLE BEVEL LOCK – Locks the table in any position from 0° to 45°.

TABLE CRANK HANDLE – Elevates and lowers the table. Turn clockwise to elevate the table. Support lock must be released before operating the crank.

TABLE LOCK – Locks the table after it is rotated to various positions.

TABLE BRACKET – Rides on the column to support the table arm and table.

WORKPIECE – Material being drilled.

ASSEMBLY AND ADJUSTMENTS

Estimated Assembly Time: 25 - 35 Minutes.

⚠ WARNING

- For your safety, never connect plug to power source receptacle until all assembly and adjustment steps are all complete, and you have read and understood the safety instructions.
- The drill press is a heavy power tool and should be lifted with the help of two people OR MORE to safely assemble it.

ASSEMBLING COLUMN TO BASE (FIG. A)

1. Position the base (2) on a flat and stable work surface (must be able to support 100 lbs.).
2. Place the column assembly (1) on the base (2). Align the three mounting holes of the column assembly to the holes of the base.
3. **Bag "G"** - Locate the three hex bolts (3) from the parts bag.
4. Place a hex bolt (3) in each hole through the column assembly and thread into the base. Tighten with a 12 mm wrench.

Fig. A

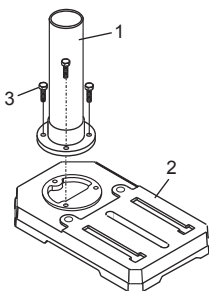

INSTALLING THE TABLE (FIG. B~F)

1. **Bag "G"** - Install the table lock handle (1) into the hole at the rear of the table bracket (4).
NOTE: Install the handle from left to right, so it enters the non-threaded side of the table bracket first.
2. **Bag "G"** - Insert the worm gear (2) into the table crank handle hole (3) from inside of the table bracket (4). Make sure the worm gear (2) meshes with the inside gear.
NOTE: Do not remove the lubrication from this worm gear.

Fig. B

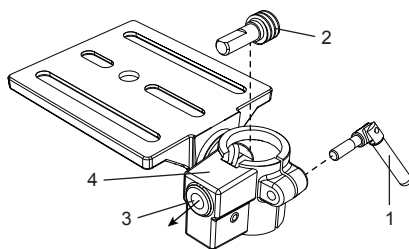

3. Place the rack (5) into the inside of table bracket (4) as shown in Fig. C, making sure the worm gear (2) in the table bracket (4) is engaged with the teeth of the rack (5) and the arrow stamped on the rack is pointing up.
4. Slide the table with the rack onto the column. (Fig. D)
5. Engage the bottom of the rack (5) with the lip of the column assembly. Tighten the table lock handle (1) to lock the table to the column assembly.
NOTE: Do not overtighten.

Fig. C

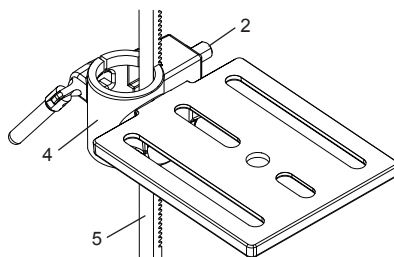
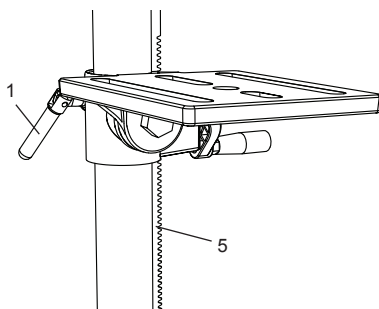

Fig. D



6. Install the rack ring (6) onto the column, so the top lip of the rack sits into the rack ring (6). (Fig. E)

NOTE: To avoid column or collar damage, DO NOT OVERTIGHTEN the set screw (7).

⚠ WARNING

The bottom of the collar **MUST NOT** be pushed all the way down onto the top of the rack. **MAKE SURE** the top of the rack is under the bottom of the collar and that there is enough clearance to allow the rack to freely rotate around the column. Tighten the set screw (7) using the 3 mm hex wrench.

Fig. E

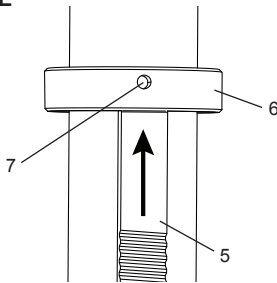

7. Install the table crank handle (8) onto the worm gear shaft (9) on the side of the table bracket. (Fig. F)
8. Line up the flat side of the shaft with the set screw (10) in the crank handle and tighten the screw with the 3 mm hex wrench provided. Do not overtighten.

Fig. F

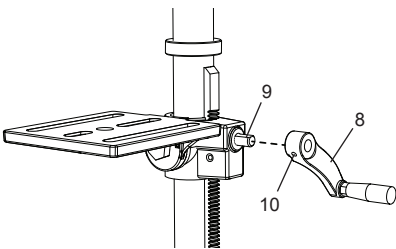

INSTALLING THE HEAD (FIG. G)

⚠ WARNING

The Drill Press head is very heavy and **MUST** be lifted with the help of 2 people **OR MORE** to safely assemble the Drill Press head on the column.

1. Carefully lift the head (1) and slide it onto the column (2). Make sure the head (1) slides down over the column as far as possible. Align the head with the base.
2. Tighten the two head locking set screws (3) on the right side of the head by using the provided 4 mm hex wrench.

Fig. G

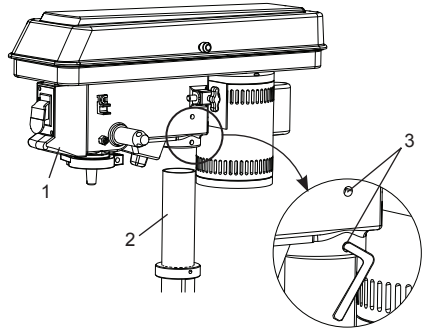

INSTALLING FEED HANDLES (FIG. H)

1. Bag "D" - Locate the three feed handles (1) in the loose parts bag.
2. Thread each feed handle (1) into the threaded holes (2) on the hub assembly (3) and tighten.

Fig. H

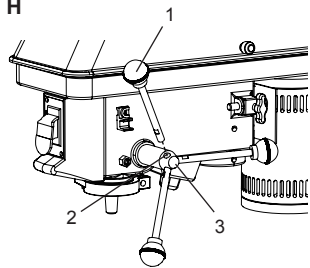

INSTALLING THE CHUCK (FIG. I, J)

⚠ WARNING

Before any assembly of the chuck and arbor to the drill press head, clean all mating surfaces with a non petroleum based product; such as alcohol or lacquer thinner. Any oil or grease used in the packing of these parts must be removed otherwise the chuck may come loose during operation.

1. **Bag "E"** - Clean out the tapered hole in the chuck (1) with a clean cloth and a non-alcohol based cleaner. Wipe clean all oil residue and any dirt or grime thoroughly. (Fig. I)
2. Clean tapered surfaces on the spindle (2) in the same manner as above.
NOTE: Make sure there are no foreign particles sticking to the surfaces. The slightest piece of dirt or oil residue on any of these surfaces will prevent the chuck from seating properly. This will cause the drill chuck and bit to wobble.
3. Open the jaws of the chuck (1) by rotating the chuck sleeve clockwise. To prevent damage, make sure the jaws are completely retracted into the chuck.
4. Unlock the table lock handle and rotate the table away from the bottom of the chuck.
5. Insert the chuck (1) onto the spindle (2), pushing upwards all the way.

Fig. I

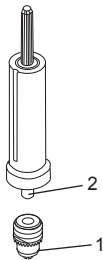

6. Using a rubber mallet or a hammer and a block of wood, tap the chuck onto the spindle firmly. (Fig. J)

Fig. J

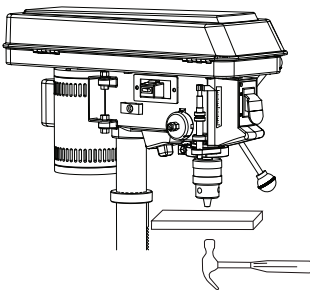

REMOVING THE CHUCK (FIG. J)

1. Turn the feed handles to lower the chuck to the lowest position.

2. Place a ball joint separator (not shown) above the chuck and tap it lightly with a hammer or rubber mallet to cause the chuck to drop from the spindle.

CAUTION

- **Never hit the chuck directly with the hammer or rubber mallet.**
- **To avoid possible damage to the chuck, raise the jaws all the way first and be prepared to catch the chuck as it falls.**

CHUCK KEY STORAGE (FIG. K)

Storage holder (1) for the chuck key (2) is located on the right side of the drill press.

Fig. K

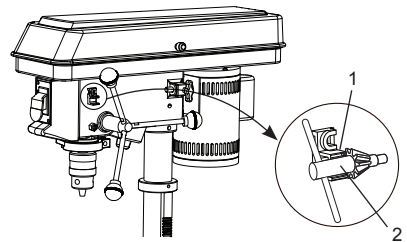

MOUNTING DRILL PRESS TO WORK SURFACE (FIG. L)

WARNING

The drill press must be securely fastened by the two base holes to a stand with heavy-duty fasteners. This will prevent the drill press from tipping over, sliding, or walking during operation.

1. If mounting the drill press to a workbench, a solid wood bench is preferred over a plywood board, to reduce noise and vibration.
2. Holes should be pre-drilled through the supporting surface.
3. The hardware to mount this drill press is NOT supplied with the tool. The hardware used are: drill press base (1), bolt (2), flat washer (3), rubber washer (4), work surface (5), flat washer (6), lock washer (7), hex nut (8), jam nut (9).

Fig. L

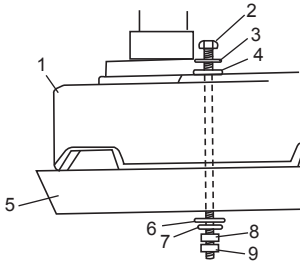

ADJUSTMENTS INSTRUCTIONS

NOTE: All the adjustments for the operation of the drill press have been completed at the factory. Due to normal wear and use, some occasional readjustments may be necessary.

⚠ WARNING

To avoid injury from an accidental start, **ALWAYS** make sure the switch is in the "OFF" position, the switch key is removed, and the plug is not connected to the power source outlet before making adjustments.

BEVEL DRILLING (FIG. M)

⚠ WARNING

To prevent personal injury, always disconnect the plug from the power source when making any adjustments.

NOTE: A bevel scale has been included to measure approximate bevel angles. If precision is necessary, a square or other measuring tool should be used to position the table. To use the bevel scale (1):

1. TIGHTEN the nut (2) on the locking pin (3) using a 10 mm or adjustable wrench clockwise to RELEASE the locking pin (3) from the table support.
2. Loosen the bevel lock bolt (4) using a 17 mm or adjustable wrench.
3. Tilt the table (5) to desired bevel angle that will shown on the bevel scale (1).
4. Tighten the bevel lock bolt (4).
5. To return the table to horizontal position, loosen the bevel lock bolt (4), return the table (5) to the 0° position.
6. Return the nut (2) on locking pin (3) to the OUTSIDE END OF THREADS. Gently tap locking pin (3) until it is seated in the mating hole of the table bracket. Hand tighten the nut (2).

Fig. M

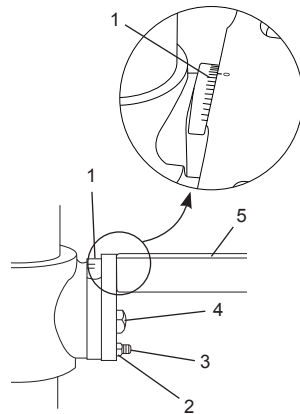

SPINDLE / QUILL (FIG. N)

Rotate the feed handles counterclockwise to lower spindle to its lowest position. Hold the chuck and move it front to back. If there is excessive play, proceed with the following adjustments:

1. Loosen the lock nut (1) located on the right side of the drill press by using a 10 mm wrench.
2. Turn the screw (2) clockwise to eliminate the play, using a slotted screwdriver, but without obstructing the upward movement of the spindle. (A little play in the spindle is normal.)
3. Tighten the lock nut (1).

Fig. N

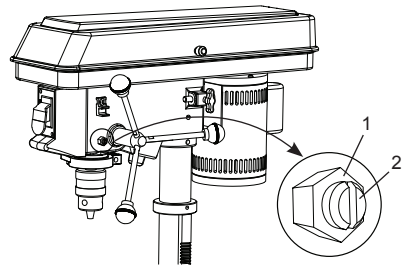

QUILL RETURN SPRING (FIG. O)

The quill return spring may need adjustment if the quill return speed is too fast or too slow. This spring is located on the left side of the drill head.

1. Lower the table for additional clearance.
2. Place a screwdriver in the lower front notch (1) of the spring cap (2). Hold it in place while loosening and removing only the outer jam nut (3), using a 10 mm wrench.
3. With the screwdriver still engaged in the notch (1), loosen the inner nut (4) just until the notch (5) disengages from the boss (6) on the drill press head.

CAUTION

DO NOT REMOVE THIS INNER NUT, because the spring will forcibly unwind.

4. Carefully turn the spring cap (2) counterclockwise with the screwdriver, engaging the next notch.
5. Lower the quill to the lowest position by rotating the feed handle in a counterclockwise direction while holding the spring cap (2) in position.
6. If the quill moves up and down as you desire, tighten the inner nut (4) against the spring cap with the wrench. If too loose, repeat steps 3 through 5 to tighten. If too tight, reverse steps 4 and 5.
7. Secure the outer nut (3) against the inner nut (4) with the wrench. **DO NOT OVERTIGHTEN** and restrict quill movement.

Fig. O

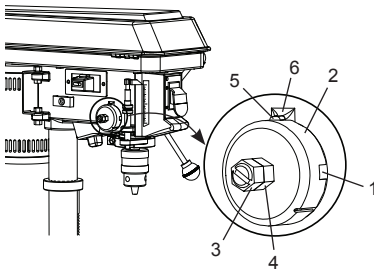

BELT TENSION (FIG. P)

WARNING

To avoid injury from an accidental start, ALWAYS make sure the switch is in the "OFF" position, the switch key is removed, and the plug is not connected to the power source outlet before making belt adjustments.

1. Open the pulley cover.
2. To unlock the belt tension, turn the belt tension lock knob (1) on the right side of the drill press head counterclockwise.
3. Pull the motor (2) toward the front of the drill press to loosen the belt tension.
4. Position the belt on the correct pulley steps for the desired speed.
5. Push the motor away from the drill press head until the belt is properly tensioned.
NOTE: Belt tension is correct if the belt deflects approximately 1/2 inch (12.7 mm) when pressed at its center.
6. Tighten the belt tension lock knob (1) to secure the motor in position. Close pulley cover.

Fig. P

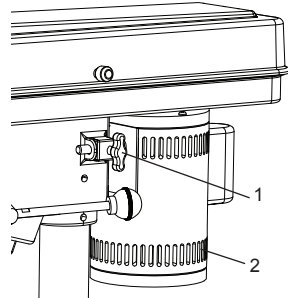

INSTALLING THE BATTERIES (FIG. Q)

1. Bag "H" - Remove the battery cover (1).
2. Install two AA batteries into the case (2).
3. Replace the battery cover (1).

Fig. Q

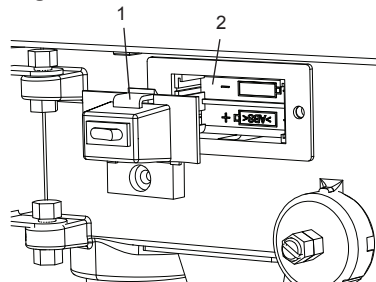

OPERATION

BASIC DRILL PRESS OPERATION

⚠ WARNING

To avoid possible injury, keep guard closed and in place while tool is in operation. To avoid injury from an accidental start, ALWAYS make sure the switch is in the "OFF" position, the switch key is removed, and the plug is not connected to the power source outlet before making belt adjustments.

SPEEDS AND BELT PLACEMENT (FIG. R)

This drill press has five operating speeds. Please see the chart in Fig. R for obtain each speed and the placement of the belt. This chart is also put on the inside of pulley cover for reference.

Fig. R

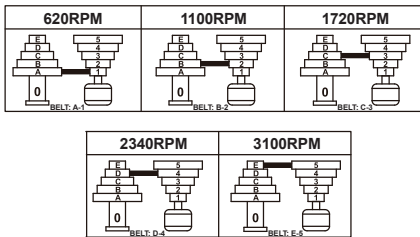

DRILLING SPEED TABLE (RPM)

Drill Bit Diameter (Inches)	Material		
	Wood	Alum. / Zinc. / Brass	Iron / Steel
1/16	3100	3100	3100
1/8			2340
3/16		2340	1720
1/4			1100
5/16		1720	1100
3/8	2340	1100	620

ON/OFF SWITCH (FIG. S)

The ON/OFF switch has a removable, safety key. With the safety key removed from the switch, unauthorized and hazardous use by children and others is minimized.

- To turn the drill press "ON", insert the safety key (1) into the slot of the switch (2). Move the switch upward to the "ON" position.
- To turn the drill press "OFF", move the switch downward.
- To lock the switch in the OFF position, grasp the sides of the safety key, and pull it out.
- With the safety key removed, the switch will not turn the power tool on.
- If the safety key is removed while the drill press is running, it can be turned "OFF" but cannot be restarted without inserting the safety key.

Fig. S

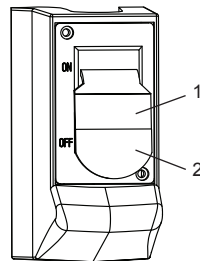

ROCKER SWITCH FOR LED LIGHT (FIG. T)

- Press the rocker switch "I" to turn the LED light "ON".
- Press the rocker switch "O" to turn the LED light "OFF".

Fig. T

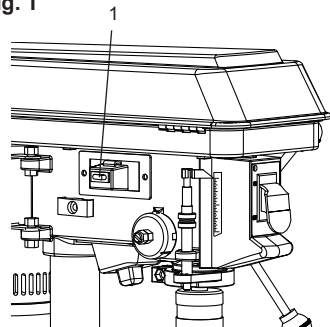

INSTALLING DRILL BIT IN CHUCK (FIG. U)

1. With the switch "OFF" and the safety key removed, open the chuck jaws (1) using the chuck key (2). Turn the chuck key counterclockwise to open the chuck jaws (1).
2. Insert the drill bit (3) into the chuck far enough to obtain maximum gripping by the jaws, but not far enough to touch the spiral grooves (flutes) of the drill bit when the jaws are tightened.
3. Make sure that the drill is centred in the chuck.
4. Turn the chuck key (2) clockwise to tighten the chuck jaws (1).

⚠ WARNING

To avoid injury or accident by the chuck key ejecting forcibly from the chuck when the power is turned "ON," use only the self-ejecting chuck key supplied with this drill press. ALWAYS recheck and remove the chuck key before turning the power "ON."

Fig. U

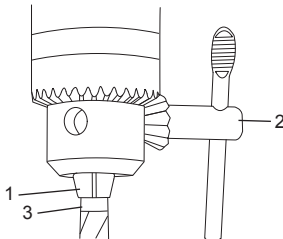

Depth scale method (Fig. W)

NOTE: With the chuck in the upper position, the tip of the drill bit must be just slightly above the top of the workpiece.

1. With the switch "OFF", turn the feed handle until the pointer (6) points to the desired depth on the depth scale (7) and hold the feed handle in that position.
2. Spin the lower nut (3) down to contact the depth stop lug (4).
3. Spin the upper nut (5) against the lower nut (3) and tighten.
4. The drill bit will stop after traveling the distance selected on the depth scale.

Fig. V

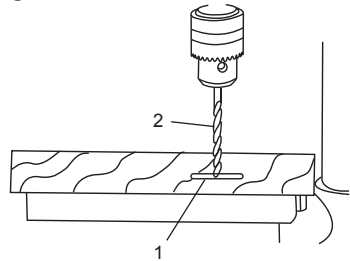
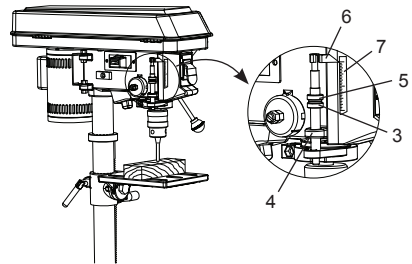

Fig. W



DRILLING TO A SPECIFIC DEPTH

Drilling a blind hole (not all the way through workpiece) to a given depth can be done two ways:

Workpiece method (Fig. V, W)

1. Make the depth mark (1) of the hole on the side of the workpiece.
2. With the switch "OFF", bring the drill bit (2) down until the tip is even with the mark (1).
3. Hold the feed handle at this position.
4. Spin the lower nut (3) down to contact the depth stop lug (4).
5. Spin the upper nut (5) down and tighten against the lower nut (3).
6. The drill bit (2) now will stop after traveling the distance marked on the workpiece.

DRILL A HOLE

Using a centre punch or a sharp nail, make an indentation in the workpiece where you want to drill. Turn the power switch on and pull down on the feed handles with only enough effort to allow the drill to cut.

FEEDING TOO RAPIDLY might cause the belt or drill to slip, tear the workpiece loose, or break the drill bit. When drilling metal, it will be necessary to lubricate the tip of the drill bit with metal drilling oil to prevent it from overheating.

BASIC OPERATION INSTRUCTIONS

To get the best results and minimize the likelihood of personal injury, follow these instructions for operating your drill press.

⚠ WARNING

For your own safety, always observe the **SAFETY INSTRUCTIONS** listed on pages 4, 5, 6 and 7 of this instruction manual when operating the drill press.

POSITIONING THE TABLE AND WORKPIECE (FIG. X, Y)

1. Lock the table (1) to the column (2) at a position so the tip of the drill bit (3) is just above the top of the workpiece (4).
2. ALWAYS place a BACK-UP MATERIAL (scrap wood) on the table beneath the workpiece. This will prevent splintering or heavy burring on the underside of the workpiece. To keep the back-up material from spinning, it MUST be positioned against the LEFT side of the column.

⚠ WARNING

To prevent the workpiece or backup material from being torn from your hands while drilling, you MUST position it against the LEFT side of the column. Failure to do this could result in personal injury.

FIG. X

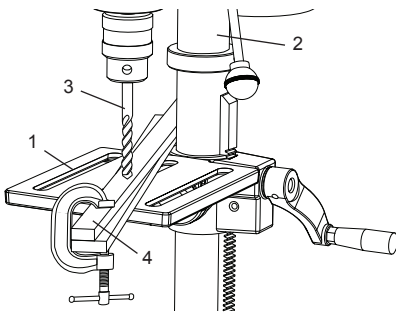

3. For a small piece that cannot be clamped to the table, use a drill press vise (optional accessory).

⚠ WARNING

When using a drill press vise, it MUST be clamped or bolted to the table to avoid injury from a spinning workpiece, or damaged vise or bit parts.

Fig. Y

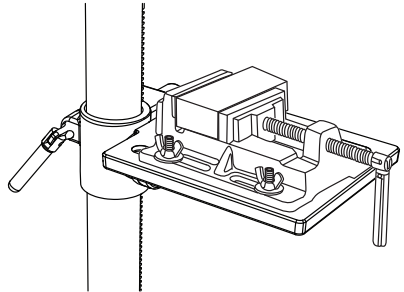

TILTING THE TABLE (FIG. Z)

1. TIGHTEN the nut (1) on the locking pin (2) using a 10 mm or adjustable wrench clockwise to RELEASE the locking pin (2) from the table support.
2. Loosen the bevel lock bolt (3) using a 17 mm or adjustable wrench and tilt the table (4) to desired bevel angle.
3. Re-tighten the bevel lock bolt (3).

⚠ WARNING

- To prevent injury, be sure to hold the table and table arm assembly, so it will not swivel or tilt.
- To avoid injury from spinning work or tool breakage, always clamp workpiece and backup material securely to the table before operating the drill press.

Fig. Z

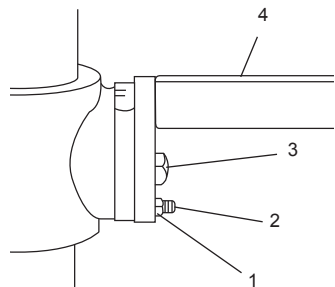

FEEDING

1. Pull down the feed handles with only enough effort to allow the drill bit to cut.
2. Feeding too slowly might cause the drill bit to burn. Feeding too rapidly might cause the belt or drill to slip, tear the workpiece loose or break the drill bit.
3. When drilling metal, it is necessary to lubricate the drill bit tip with oil to prevent burning of the workpiece and bit.

MAINTENANCE

⚠ WARNING

For your own safety, turn the switch off and remove the plug from the power source outlet before maintaining or lubricating your drill press.

GENERAL MAINTENANCE

Frequently blow out dust and grit that accumulates in the motor housing using compressed air.

⚠ WARNING

ALWAYS use safety glasses. Everyday eyeglasses are NOT safety glasses. Also use face or dust mask if cutting operation is dusty. ALWAYS WEAR CERTIFIED SAFETY EQUIPMENT:

- ANSI Z87.1 eye protection (CAN/CSA Z94.3),
- ANSI S12.6 (S3.19) hearing protection,
- NIOSH/OSHA/MSHA respiratory protection.

A coat of automotive paste wax applied to the table and column will help to keep the surface clean.

⚠ WARNING

To avoid shock or fire hazard, if the power lead is worn or cut in any way, replace it immediately.

LUBRICATION

Ball bearings in the drill press are packed with grease at the factory and require no further lubrication.

Use only mild soap and a damp cloth to clean the tool. Never let any liquid get inside the tool; never immerse any part of the tool into a liquid.

IMPORTANT: To assure product SAFETY and RELIABILITY, repairs, maintenance and adjustment (other than those listed in this manual) should be performed by authorized service centers or other qualified service organizations, always using identical replacement parts.

To clean cast iron parts of rust, you will need the following materials (not supplied): scouring pad, spray lubricant, can of degreaser. Apply the spray lubricant and polish with surface with the scouring pad. Degrease the surface, then apply a protective product such as an automotive paste wax.

ACCESSORIES AND ATTACHMENTS

AVAILABLE ACCESSORIES

⚠ WARNING

Since accessories, other than those offered by Porter-Cable, have not been tested with this product, use of such accessories with this tool could be hazardous. To reduce the risk of injury, only Porter-Cable recommended accessories should be used with this product.

A complete line of accessories is available from your Porter-Cable Factory Service Center or a Porter-Cable Authorized Warranty Service Center. Please visit our Website www.portercable.com for a catalog or for the name of your nearest supplier.

⚠ WARNING

Do not use any accessory unless you have completely read the Instruction Manual for that accessory.

TROUBLESHOOTING GUIDE

WARNING

To avoid injury from an accidental start, turn the switch OFF and always remove the plug from the power source before making any adjustments.

REPLACEMENT PARTS

Use only identical replacement parts. For a parts list or to order parts, visit our service website at www.portercable.com. You can also order parts from your nearest Porter-Cable Factory Service Center or Porter-Cable Authorized Warranty Service Center. Or, you can call our Customer Care Center at (888) 609-9779.

SERVICE AND REPAIRS

All quality tools will eventually require servicing and/or replacement of parts. For information about Porter-Cable, its factory service centers or authorized warranty service centers, visit our website at www.portercable.com or call our Customer Care Center at (888) 609-9779. All repairs made by our service centers are fully guaranteed against defective material and workmanship. We cannot guarantee repairs made or attempted by others.

You can also write to us for information at Power Tool Specialists, Inc. 684 Huey Road, Rock Hill, SC 29730, - Attention: Product Service. Be sure to include all of the information shown on the nameplate of your tool (model number, type, serial number, etc.).

PROBLEM	PROBLEM CAUSE	SUGGESTED CORRECTIVE ACTION
Noisy operation	<ol style="list-style-type: none">1. Incorrect belt tension.2. Dry spindle.3. Loose spindle pulley.4. Loose motor pulley.	<ol style="list-style-type: none">1. Adjust tension. See section "Assembly - Belt Tension".2. Lubricate spindle.3. Check tightness of retaining nut on pulley, and tighten if necessary.4. Tighten set screw in motor pulley.
Drill bit burns	<ol style="list-style-type: none">1. Incorrect speed.2. Chips not coming out of hole.3. Dull drill bit.4. Feeding too slowly.5. Not lubricated.	<ol style="list-style-type: none">1. Change speed. See Section "Operation - Speeds and Belt Placement Table".2. Retract drill frequently to clear chips.3. Resharpen drill bit.4. Feed fast enough – allow drill to cut.5. Lubricate drill.
Run out of drill bit point/ drilled hole not round.	<ol style="list-style-type: none">1. Grain in wood or lengths of cutting flutes and/or angles not equal.2. Bent drill bit.	<ol style="list-style-type: none">1. Resharpen drill bit correctly.2. Replace drill bit.
Wood splinters on underside.	<ol style="list-style-type: none">1. No backup material under workpiece.	<ol style="list-style-type: none">1. Use backup material. See Section "BASIC DRILL PRESS OPERATION".
Workpiece torn loose from hand.	<ol style="list-style-type: none">1. Not supported or clamped properly.	<ol style="list-style-type: none">1. Support workpiece or clamp it. See Section "BASIC DRILL PRESS OPERATION".

PROBLEM	PROBLEM CAUSE	SUGGESTED CORRECTIVE ACTION
Drill bit binds in workpiece.	<ol style="list-style-type: none"> 1. Workpiece pinching drill bit, or excessive feed pressure. 2. Improper belt tension. 	<ol style="list-style-type: none"> 1. Support workpiece or clamp it. See Section "BASIC DRILL PRESS OPERATION". 2. Adjust tension. See Section "Assembly - Belt Tension".
Excessive drill bit runout or wobble.	<ol style="list-style-type: none"> 1. Bent drill bit. 2. Worn bearings. 3. Drill bit not properly installed in chuck. 4. Chuck not properly installed. 	<ol style="list-style-type: none"> 1. Replace drill bit. 2. Replace bearings. 3. Install drill properly. See Section "BASIC DRILL PRESS OPERATION" and "ASSEMBLY". 4. Install chuck properly. See Section "ASSEMBLY INSTALLING THE CHUCK".
Quill returns too slow or too fast.	<ol style="list-style-type: none"> 1. Coil spring has improper tension. 	<ol style="list-style-type: none"> 1. Adjust spring tension. See Section "ASSEMBLY ADJUSTMENTS QUILL/RETURN SPRING".
Chuck will not stay attached to spindle. It falls off when trying to install.	<ol style="list-style-type: none"> 1. Dirt, grease, or oil on the tapered inside surface of chuck or on the spindle's tapered surface. 	<ol style="list-style-type: none"> 1. Using a non-alcohol based cleaner, clean the tapered surface of the chuck and spindle to remove all dirt, grease and oil. See Section "ASSEMBLY INSTALLING THE CHUCK".

For assistance with your product, visit our website at www.portercable.com for a list of service centers, or call the Porter-Cable Customer Care Center at (888) 609-9779.

PARTS LIST

10 IN. (254 MM) DRILL PRESS PARTS LIST

I.D. No.	Description	Size	Q'ty	I.D. No.	Description	Size	Q'ty
X758	PULLEY SET NUT	1"-20	1	X773	QUILL SET SCREW	M8*1.25-14	1
X759	BATTERY	AA	2	X774	HEX. NUT	M8*1.25 T=6.5	1
X75A	SWITCH KEY		1	X778	SPRING PIN		1
X75C	POWER CORD		1	X779	NUT	M8*1.25 T=8	2
X75D	INSTRUCTION MANUAL		1	X77A	HEX. SCREW	M8*1.25-25	2
X75L	BASE		1	X77B	MOTOR ROD ASS'Y		1
X75N	HEX. BOLT	M8*1.25-25	3	X77C	COMPRESSION SPRING		1
X75Q	RACK		1	X77D	FLAT WASHER		4
X75T	HEX. BOLT	1/2*12UNC-7/8	1	X77E	FEED SHAFT		1
X75U	WORK TABLE		1	X77F	HEAD		1
X75X	ANGLE SCALE		1	X77G	SHIFTER BOLT		1
X75Z	TABLE LOCK HANDLE		1	X77H	CHUCK KEY HOLDER		1
X760	HEX. WRENCH		1	X77J	RUBBER SLEEVE	φ20	2
X761	HEX. WRENCH		1	X77K	V-BELT		1
X762	WORM ROD		1	X77L	CR. RE. COUNT HD. SCREW	M6*1.0-12	5
X766	CHUCK KEY		1	X77M	CORD CLAMP		3
X768	HEX. SOC. SCREW	M6*20	1	X77N	CR. RE. PAN HD. SCREW	M5*0.8-12	6
X769	HEX. NUT	M6	2	X77P	PULLEY COVER ASS'Y		1
X76A	FLAT WASHER	φ6	1	X77W	SPINDLE PULLEY		1
X76B	DEPTH SCALE BASE		1	X77X	PULLEY SET NUT	M8*10	3
X76H	TERMINAL		1	X7AZ	BATTERY BOX ASS'Y		1
X76J	ON/OFF SWITCH		1	X7B0	QUILL ASS'Y		1
X76K	SWITCH PLATE		1	X7B1	CHUCK & KEY		1
X76L	SWITCH BOX		1	X7B2	LOCATION PIN ASS'Y		1
X76M	DEPTH SCALE		1	X7B3	COLUMN ASS'Y		1
X76N	NUT	M10*1.5-2B	2	X7B4	TABLE BRACKET ASS'Y		1
X76P	SET BOLT	M10*1.5	1	X7B5	CRANK HANDLE ASS'Y		1
X76Q	POINTER		1	X7B6	RACK RING ASS'Y		1
X76R	CR. RE. PAN HD. SCREW	M4*10	2	X7B7	SPRING CAP ASS'Y		1
X76S	CR. RE. PAN HD. TAPPING SCREW	S4.2*12	4	X7B8	MOTOR ASS'Y		1
X76T	LED BASE		1	X7B9	HANDLE BAR ASS'Y		1
X76U	LED COVER		1	X7BA	MOTOR PULLEY ASS'Y		1
X76V	LED LAMP		1	X7BB	DRIVING SLEEVE ASS'Y		1
X76W	LED PRESSURE PLATE		1	X7BE	CORD PLATE		1
X76X	HEX. NUT	3/8*24UNF T=8	2				
X770	CR. RE. PAN HD. SCREW	M5*0.8-8	2		HARDWARE BAG		
X771	STAR WASHER	φ5	2	X7B1	CHUCK & KEY		1
X772	EARTH MARK		1	X7B9	HANDLE BAR ASS'Y		1

**10 IN. (254 MM) DRILL PRESS
SCHEMATIC**

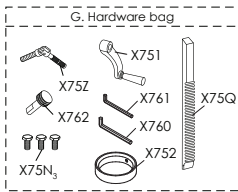
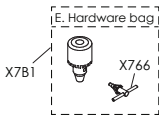
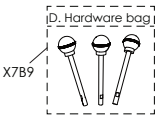
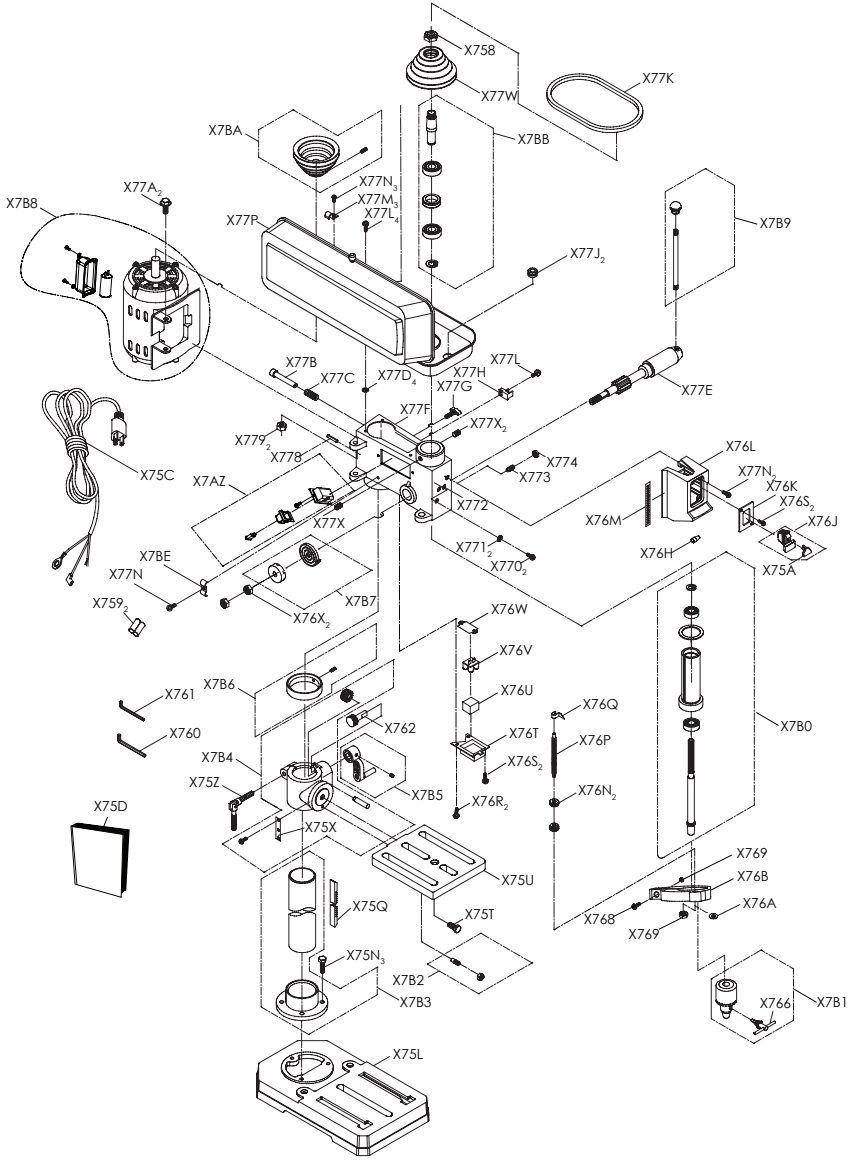

WARRANTY

THREE YEAR LIMITED WARRANTY

PORTER-CABLE will repair, without charge, any defects due to faulty materials or workmanship for three years from the date of purchase. This warranty does not cover part failure due to normal wear or tool abuse. For further detail of warranty coverage and warranty repair information, visit www.portercable.com or call (888) 609-9779. This warranty does not apply to accessories or damage caused where repairs have been made or attempted by others. This warranty gives you specific legal rights and you may have other rights which vary in certain states or provinces.

In addition to the warranty, PORTER-CABLE tools are covered by our:

1 YEAR FREE SERVICE: PORTER-CABLE will maintain the tool and replace worn parts caused by normal use, for free, any time during the first year after purchase.

90 DAYS MONEY BACK GUARANTEE: If you are not completely satisfied with the performance of your PORTER-CABLE Power Tool for any reason, you can return it within 90 days from the date of purchase with a receipt for a full refund – no questions asked.

LATIN AMERICA: This warranty does not apply to products sold in Latin America. For products sold in Latin America, see country specific warranty information contained in the packaging, call the local company or see website for warranty information.

To register your tool for warranty service visit our website at www.portercable.com.

WARNING LABEL REPLACEMENT

If your warning labels become illegible or are missing, call (888) 609-9779 for a free replacement.

The following are PORTER-CABLE trademarks for one or more power tools and accessories: a gray and black color scheme; a “four point star” design; and three contrasting/outlined longitudinal stripes. The following are also trademarks for one or more Porter-Cable and Delta products: 2 BY 4®, 890™, Air America®, AIRBOSS™, Auto-Set®, B.O.S.S.®, Bammer®, Biesemeyer®, Builders Saw®, Charge Air®, Charge Air Pro®, CONTRACTOR SUPERDUTY®, Contractor’s Saw®, Delta®, DELTA®, Delta Industrial®, DELTA MACHINERY & DESIGN™, Delta Shopmaster and Design®, Delta X5®, Deltacraft®, DELTAGRAM®, Do It. Feel it.®, DUAL LASERLOC AND DESIGN®, EASY AIR®, EASY AIR TO GO™, ENDURADIAMOND®, Ex-Cell®, Front Bevel Lock®, Get Yours While the Sun Shines®, Grip to Fit®, GRIPVAC™, GTF®, HICKORY WOODWORKING®, Homecraft®, HP FRAMER HIGH PRESSURE®, IMPACT SERIES™, Innovation That Works®, Jet-Lock®, Job Boss®, Kickstand®, LASERLOC®, LONG-LASTING WORK LIFE®, MAX FORCE™, MAX LIFE®, Micro-Set®, Midi-Lathe®, Monsoon®, MONSTER-CARBIDE™, Network®, OLDHAM®, Omnijig®, PC EDGE®, Performance Crew™, Performance Gear®, Pocket Cutter®, Porta-Band®, Porta-Plane®, Porter-Cable®, Porter-Cable Professional Power Tools®, Powerback®, POZI-STOP™, Pressure Wave®, PRO 4000®, Proair®, Quicksand and Design®, Quickset II®, QUIET DRIVE TECHNOLOGY™, QUIET DRIVE TECHNOLOGY AND DESIGN™, Quick-Change®, QUIK-TILT®, RAPID-RELEASE™, RAZOR®, Redefining Performance®, Riptide®, Safe Guard II®, Sand Trap and Design®, Sanding Center®, Saw Boss®, Shop Boss®, Sidekick®, Site Boss®, Speed-Bloc®, Speedmatic®, Stair Ease®, Steel Driver Series®, SUPERDUTY®, T4 & DESIGN®, THE AMERICAN WOODSHOP®, THE PROFESSIONAL EDGE®, Thin-Line®, Tiger Saw®, TIGERCLAW®, TIGERCLAW AND DESIGN®, Torq-Buster®, TRU-MATCH®, T-Square®, Twinlaser®, Unifence®, Uniguard®, UNIRIP®, UNISAW®, UNITED STATES SAW®, Veri-Set®, Versa-Feeder®, VIPER®, VT™, VT RAZOR™, Water Driver®, WATER VROOM®, Waveform®, Whisper Series®, X5®, YOUR ACHIEVEMENT. OUR TOOLS.®, Trademarks noted with ® are registered in the United States Patent and Trademark Office and may also be registered in other countries. Other trademarks may apply.

PORTER-CABLE and the PORTER-CABLE logo are registered trademarks of PORTER-CABLE and are used under license. All rights reserved.

PORTER  CABLE.

Power Tool Specialists, Inc.
684 Huey Road, Rock Hill, SC 29730
(888) 609-9779
www.portercable.com